

ILLUSTRATED PARTS LIST

MFG. ID NO. 96041043600

CUSTOMER CATALOG NO. TS 146TXD

PRODUCT NO. 960 41 04-36

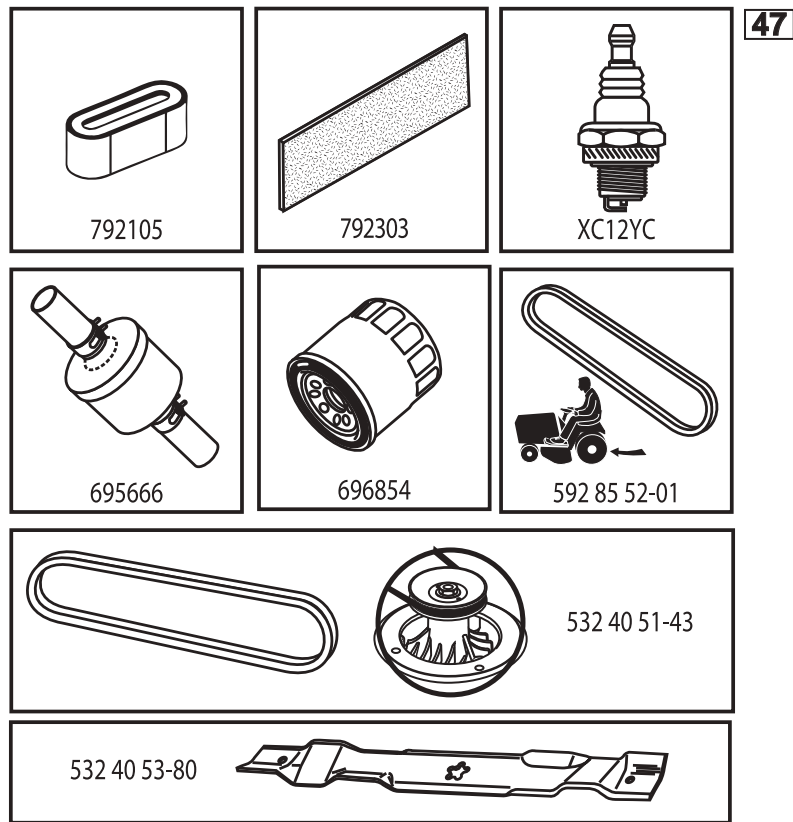

595901001

TRACTOR -- MODEL NO. TS 146TXD (96041043600), PRODUCT NO. 960 41 04-36
DECALS 27

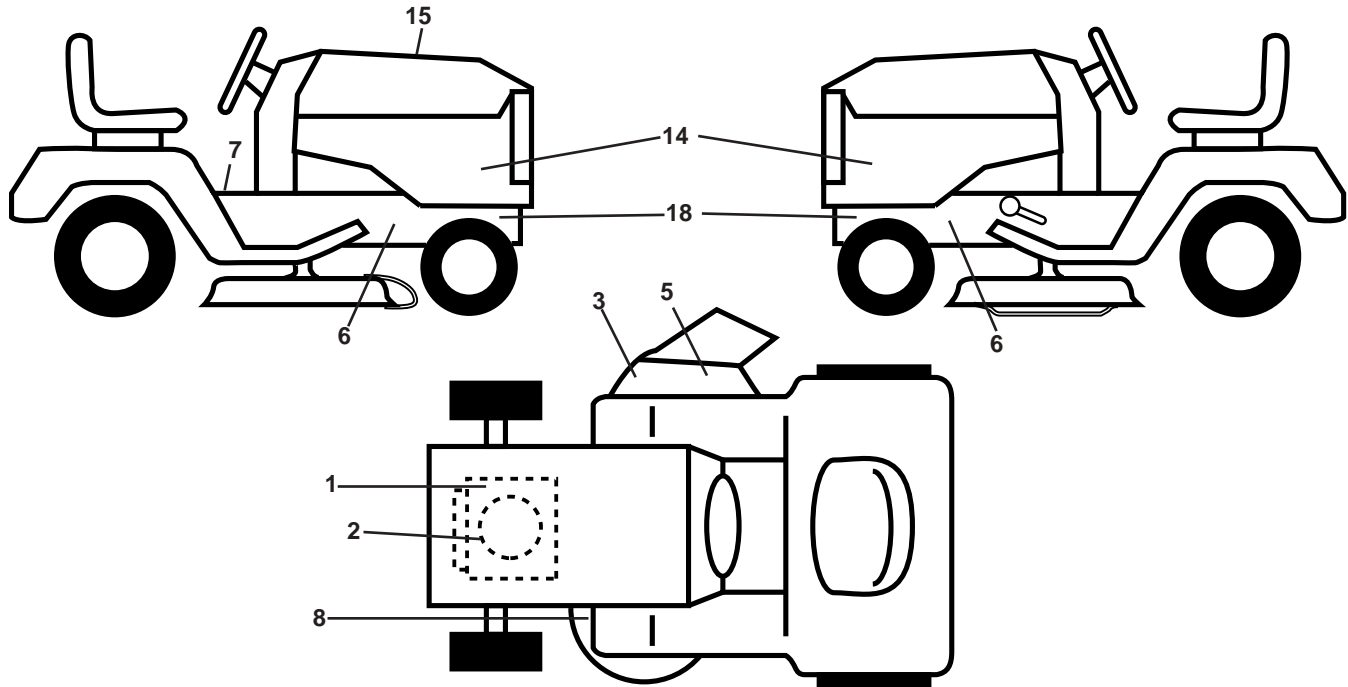

KEY NO.	PART NO.	DESCRIPTION
1	581 57 97-01	Decal, Engine Warning
2	587 46 91-01	Decal, Engine
3	581 57 92-01	Decal, Warning
5	584 90 46-01	Decal, Deflect. Warning
6	581 57 98-01	Decal, Warning
7	586 35 06-01	Decal, Warning Symbols
8	581 58 00-01	Decal, Mower Sch.
14	598 42 85-01	Decal, Panel Side
15	595 90 10-01	Decal, Replacement Parts
18	581 57 96-01	Decal, Chassis Hot Muffler

KEY NO.	PART NO.	DESCRIPTION
--	581 72 46-01	Decal, Drawbar Load Limit
--	581 72 48-01	Decal, Bypass
--	532 43 98-82	Pad, Footrest, LH
--	532 43 98-81	Pad, Footrest, RH
--	114 20 27-20	Manual, Operator's (Euro)
--	114 20 28-10	Manual, Operator's (Scan)
--	114 20 29-50	Manual, Operator's (E-bloc)
--	114 20 30-40	Manual, Operator's (Baltic)
--	114 20 31-76	Manual, Operator's (Turkish)
--	114 20 32-53	Manual, Operator's (Ukrainian)

WHEELS AND TIRES

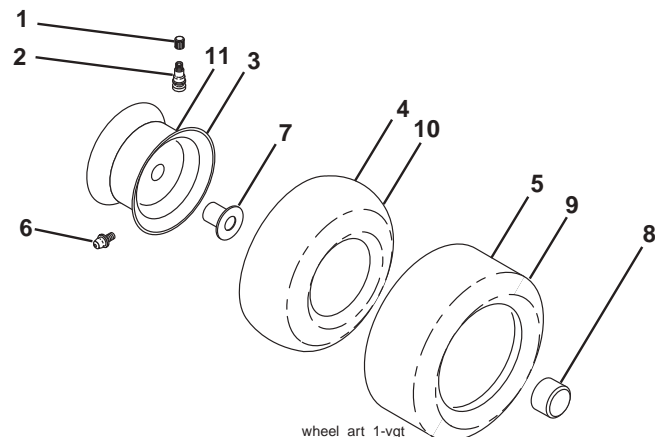

KEY NO.	PART NO.	DESCRIPTION
1	532 05 91-92	Cap, Valve, Tire
2	532 06 51-39	Stem, Valve
3	532 13 83-36	Rim Assembly, Front
4	532 05 99-04	Tube, Front (Service Item Only)
5	532 17 04-55	Tire, Front 15 x 6-6
6	532 00 02-78	Fitting, Grease (Front Wheel Only)
7	532 00 90-40	Bearing, Flange (Front Wheel Only)
8	532 17 50-39	Cap, Axle (Front Wheel Only)
9	532 17 04-56	Tire, Rear 20 x 10-8
10	532 00 71-52	Tube, Rear (Service Item Only)
11	532 13 83-37	Rim Assembly, Rear
--	532 14 43-34	Sealant, Tire (10 oz. Tube)

NOTE: All component dimensions given in U.S. inches
 1 inch = 25.4 mm

TRACTOR -- MODEL NO. TS 146TXD (96041043600), PRODUCT NO. 960 41 04-36 SCHEMATIC **38**

SCH13

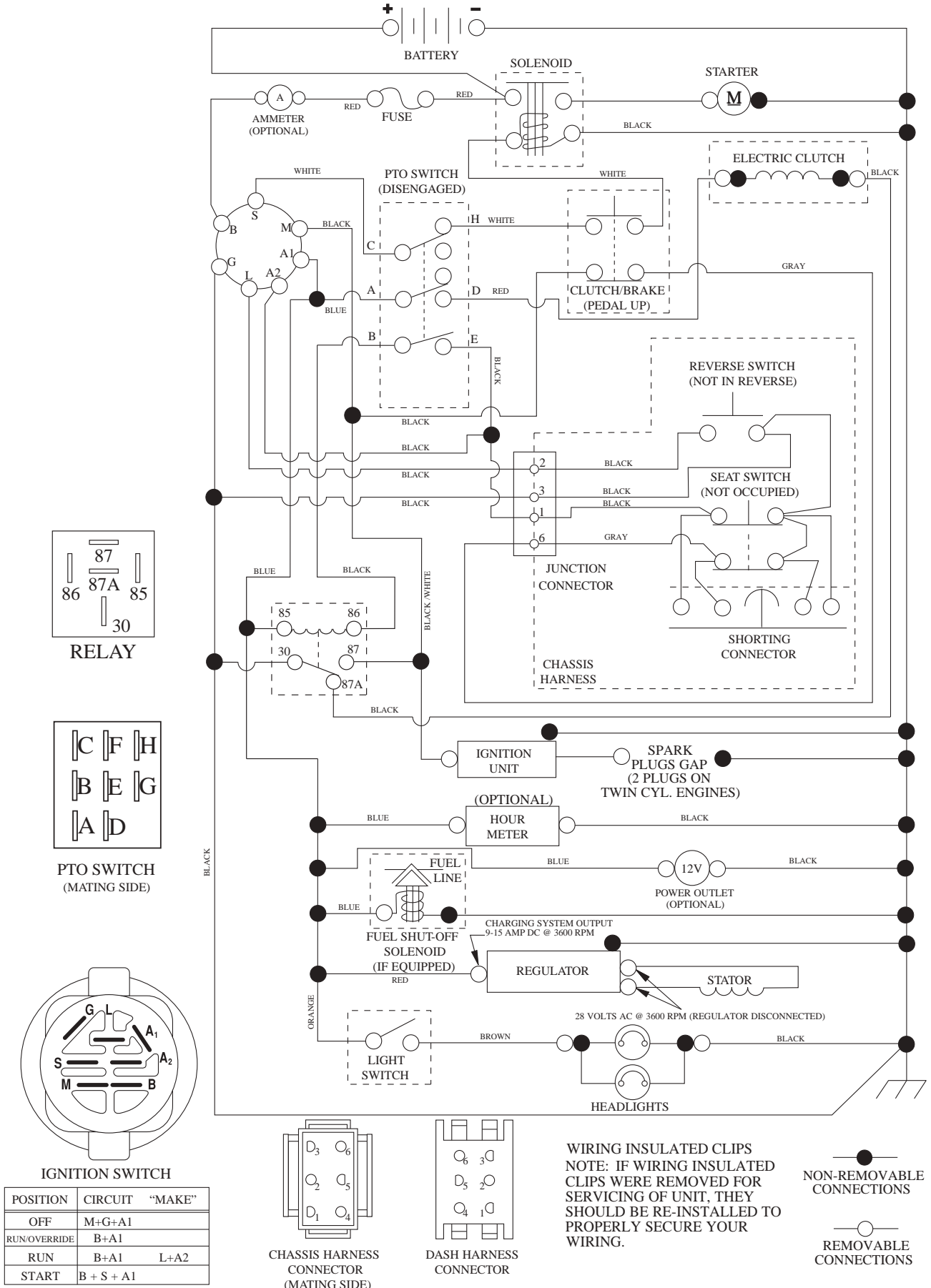

TRACTOR -- MODEL NO. TS 146TXD (96041043600), PRODUCT NO. 960 41 04-36
ELECTRICAL 32

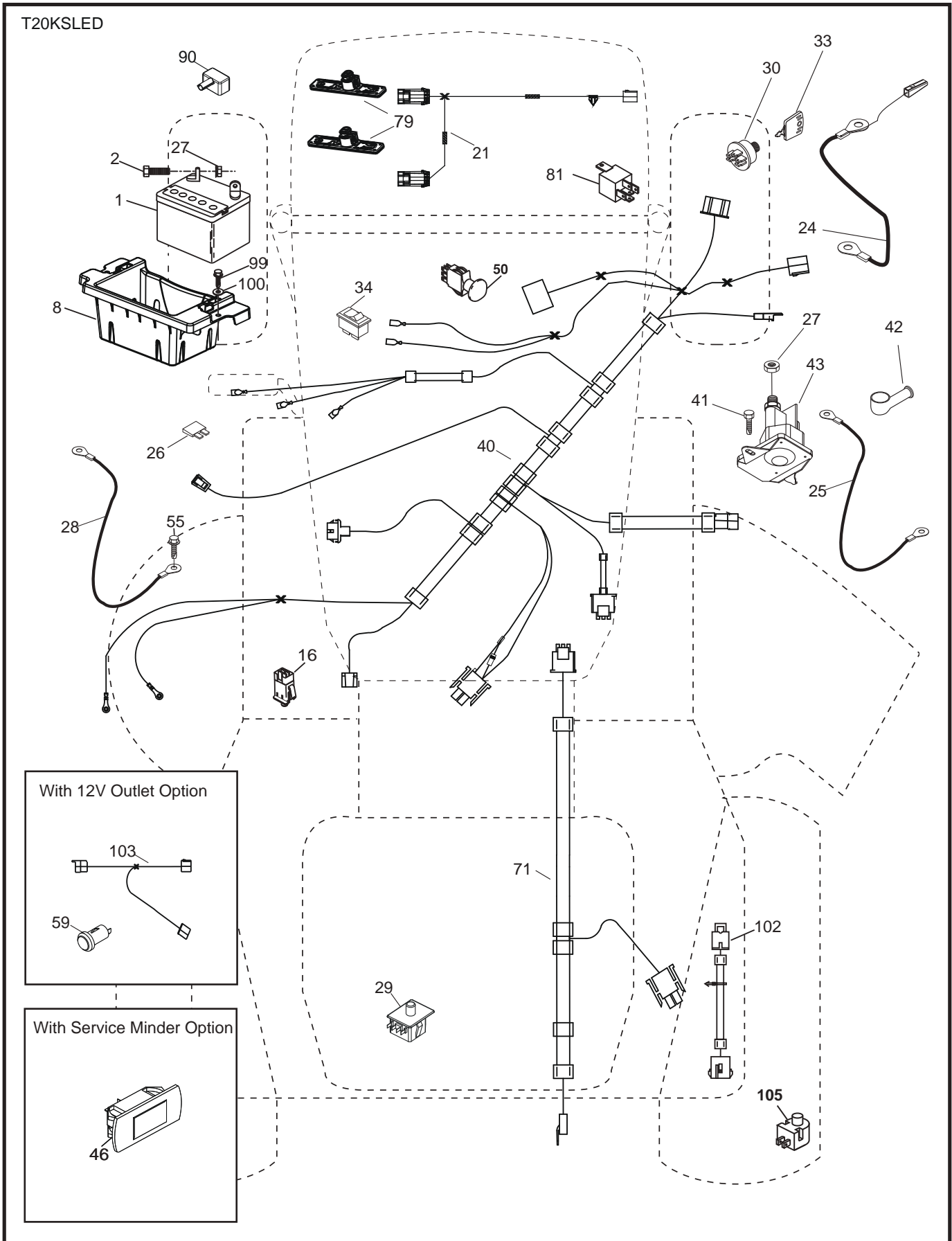

**TRACTOR - - MODEL NO. TS 146TXD (96041043600), PRODUCT NO. 960 41 04-36
ELECTRICAL 32**

KEY NO.	PART NO.	DESCRIPTION
1	532 16 34-65	Battery
2	874 76 04-12	Bolt Hex Hd. 1/4-20 unc x 3/4
8	587 20 51-01	Battery Box
16	532 17 61-38	Switch Interlock
21	585 43 64-02	Harness, LED Lights
24	585 55 56-01	Cable Battery
25	585 55 55-01	Cable Starter
26	532 17 51-58	Fuse
27	596 13 36-01	Locknut, Keps, 1/4-20
28	532 41 65-88	Cable Ground
29	532 19 27-49	Switch, Seat
30	532 19 33-50	Switch Ign Delta
33	532 41 19-35	Key/Chain
34	532 11 07-12	Switch Light
40	501 13 32-01	Harness Ign. Dash
41	817 72 04-08	Screw 1/4-20 x 1/2
42	532 13 15-63	Cover Terminal
43	582 04 28-02	Solenoid w/Brass Plunger An
46	594 91 91-01	Hourmeter, SRVminder
50	582 10 76-02	Switch PTO
55	817 06 05-12	Screw 5/16-18 x 3/4
71	532 19 42-76	Harness Ign. Chassis
79	597 52 30-01	Light, LED Bar
81	532 40 96-15	Relay Harness
90	532 43 53-95	Cover Terminal Battery
99	817 67 04-12	Screw Hex Wsh. Thdrol. 1/4-20 x 3/4
100	596 13 53-01	Washer, Plain, 9/32 x 7/8, Clr, Zn
102	532 40 44-54	Harness Pigtail Tex ROS Tufftorq
105	532 40 75-68	Switch Reverse

NOTE: All component dimensions given in U.S. inches
1 inch = 25.4 mm

TRACTOR -- MODEL NO. TS 146TXD (96041043600), PRODUCT NO. 960 41 04-36
CHASSIS AND ENCLOSURES **39**

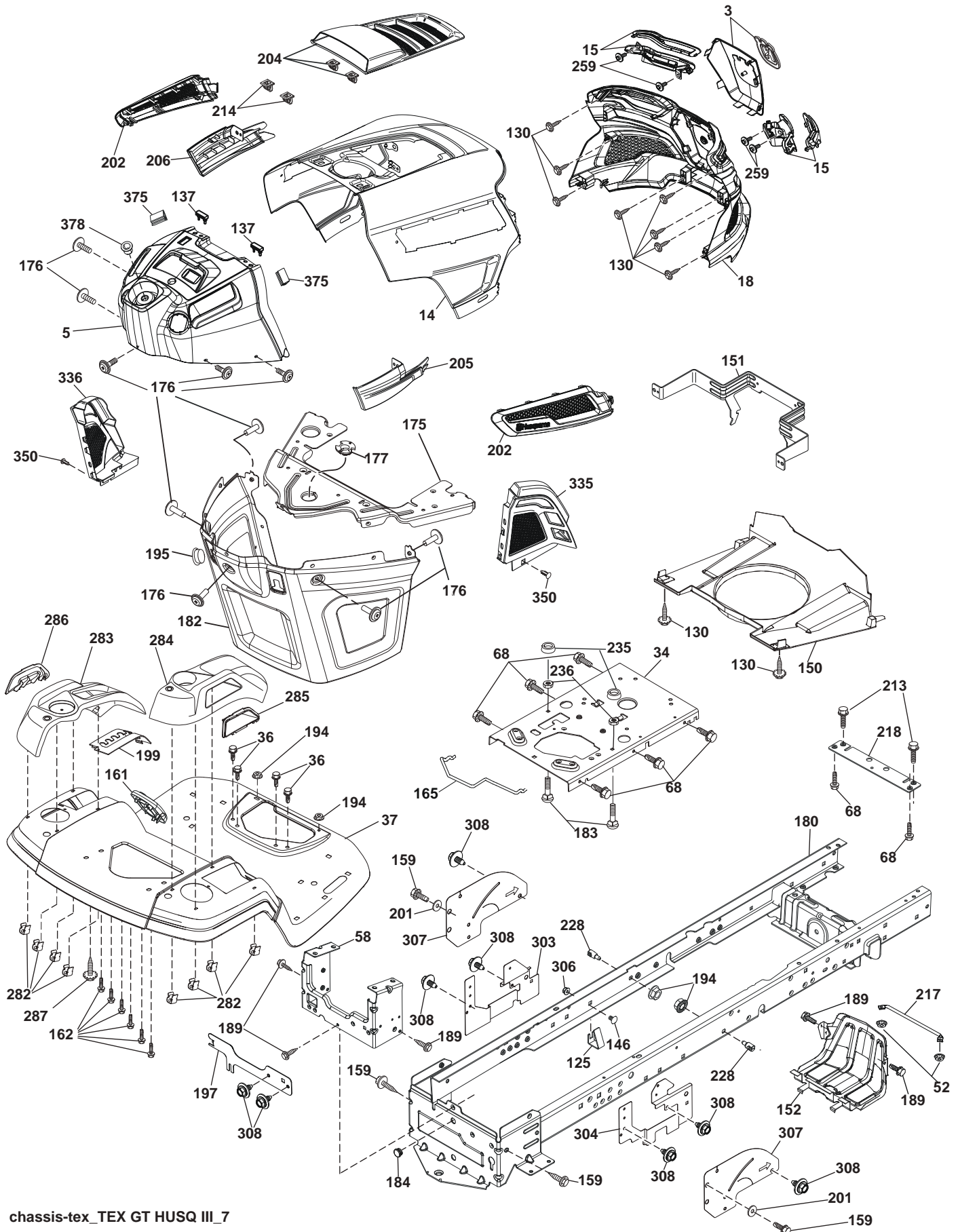

chassis-tex_TEX GT HUSQ III_7

**TRACTOR -- MODEL NO. TS 146TXD (96041043600), PRODUCT NO. 960 41 04-36
CHASSIS AND ENCLOSURES 39**

KEY NO.	PART NO.	DESCRIPTION	KEY NO.	PART NO.	DESCRIPTION
3	597 68 82-01	Kit, Grille Applique, (includes applique cover and emblem badge)	197	589 20 46-02	Shield Drawbar
5	590 74 88-21	Dash	199	532 41 34-85	Plate Deck
14	532 44 11-77	Hood	201	819 13 20-16	Washer 13/32 x 1-1/4 x 16 Ga.
15	597 86 79-01	Kit, SVC, Hus GT3, LED Headlights (includes LH/RH lens and LH/RH housing)	202	597 86 77-01	Kit, Side Vents, LH/RH (includes LH/RH side vents)
18	597 40 71-02	Grille	204	597 40 80-01	Kit, Top Vent (includes top vent and clip retainers)
34	580 91 08-01	Plate Engine	205	532 43 97-30	Skirt Side RH
36	817 06 05-12	Screw 5/16-18 x 3/4	206	532 43 97-29	Skirt Side LH
37	532 44 11-78	Fender	213	596 03 05-01	Bolt, Hex, Hd, 5/16-18 unc x 3/4
52	596 04 05-01	Nut, Lock, Hex, Prvl 5/16-18	214	532 19 91-45	Clip Retainer
58	532 41 22-80	Drawbar, Upper, 2 Pc, Sml, Fender	217	532 40 91-67	Rod Pivot Hood
68	596 03 07-01	Screw, Hexagon, 5/16-18 x 1/2	218	532 19 63-95	X-Piece Hood Stop
125	581 68 48-01	Clip Fuel Line	228	593 82 40-01	Stud w/"D" Anti-Rotation
130	596 32 17-01	Screw #10 x 0.750	235	596 56 42-01	Spacer Fender
137	532 40 75-90	Bumper Dash	236	873 93 05-00	Nut Lock 5/16-18 unc
146	581 85 79-01	Bolt	259	596 43 40-01	Screw #10.10 x 0.500, Bos Thread
150	532 43 97-74	Air Duct	282	532 41 41-10	Clip Retianer
151	532 43 66-70	Bracket Pivot	283	532 43 98-61	Console Deck Lift
152	532 43 98-70	Shield Browning	284	532 43 98-23	Console Control
159	817 00 06-12	ScrewmHexwsh,Thdr3/8-16x3/4BL	285	532 41 63-15	Console Insert RH
161	532 43 97-81	Window, Fuel	286	532 41 63-17	Console Insert LH
162	596 13 41-01	Screw, Hex, Tap, 1/4-15 x 1/2	287	817 60 04-06	Screw Hex Washhead 1/4-20 x 3/8
165	532 19 68-26	Support Rear	303	589 00 81-02	Shield Lower LH
175	590 60 77-02	Crossmember	304	589 00 90-02	Shield Lower RH
176	532 40 07-76	Screw 10-24 x 5/8	306	873 90 06-00	Nut 3/8-16 unc
177	532 19 52-28	Bushing Steering	307	587 49 46-01	Shield, Upper, LT Fender
180	532 41 50-64	Chassis	308	532 17 18-77	Bolt 5/16-18 unc x 3/4
182	532 40 68-59	Dash Lower	335	532 44 82-04	Cover RH Lower Close Out
183	595 30 57-01	Screw, Hexagon, 5/16-18 x 1-1/4	336	532 44 53-09	Cover Lower Dash LH
184	587 55 41-01	Plug Dome	350	532 44 51-43	Clip X-mas Tree
189	817 00 05-12	Screw 5/16-18 x 3/4	375	586 90 82-01	Dash Clip-On Bumper
194	596 13 57-01	Nut, Lock, Prvl, Torq, 5/16-18 x .68	378	590 84 98-01	Bushing, Flange
195	532 40 41-37	Plug Hole Dash	NOTE: All component dimensions given in U.S. inches 1 inch = 25.4 mm		

TRACTOR -- MODEL NO. TS 146TXD (96041043600), PRODUCT NO. 960 41 04-36
DRIVE **40**

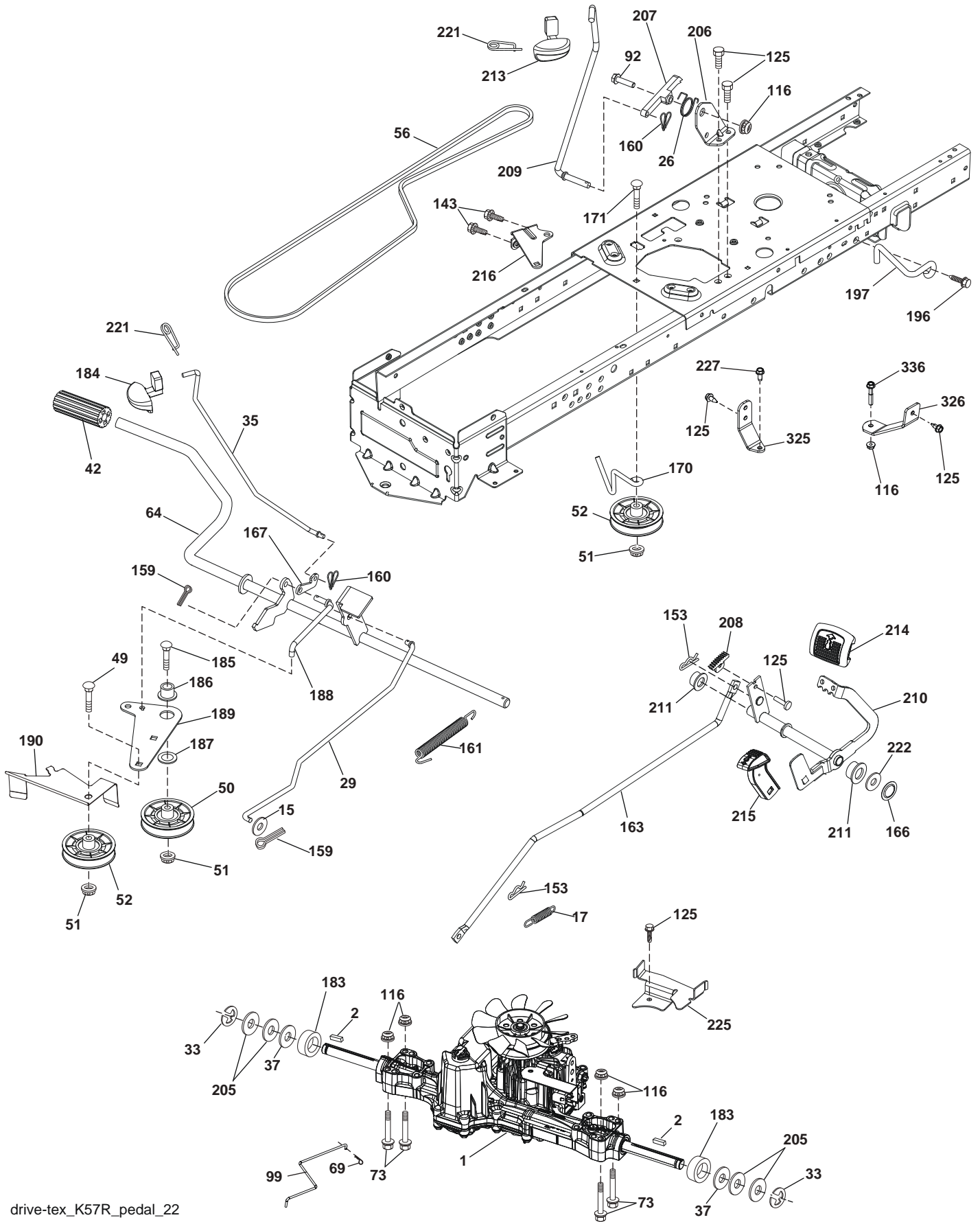

**TRACTOR -- MODEL NO. TS 146TXD (96041043600), PRODUCT NO. 960 41 04-36
DRIVE **40****

KEY NO.	PART NO.	DESCRIPTION	KEY NO.	PART NO.	DESCRIPTION
1	---	Transaxle, TuffTorq 46CR (501051401) (Order parts from transaxle manufacturer.)	183	532 13 70-57	Spacer Axle
2	532 12 35-83	Key	184	587 65 37-01	Handle Parking Brake
15	596 56 53-01	Washer, 3/8 x 0.08 In. St, Clr, Zinc	185	872 11 06-22	Bolt
17	532 41 36-78	Spring, Brake	186	532 19 43-21	Spacer Retainer
26	532 19 96-79	Spring Return Cruise	187	596 13 55-01	Washer, 13/32 x 2, clear, zinc
29	532 40 38-06	Rod, Brake	188	582 21 70-01	Link Clutch Ground Drive, Long
33	812 00 00-01	Ring E	189	532 19 43-17	Bellcrank Ground Drive
35	583 86 45-02	Rod, Brake, Park	190	532 19 43-18	Keeper Bellcrank Ground Drive
37	532 18 89-67	Washer Hardened	196	817 00 06-16	Screw 3/8-16 x 1
42	532 00 88-83	Cover, Foot Pedal	197	585 65 86-02	Clutch, Antirotation, Wireform
49	596 13 62-01	Bolt.cup, Head, 3/8-16 x 3/4	205	532 12 17-48	Washer 25/32 x 1-5/8 x 16 Ga.
50	532 19 43-27	Pulley Idler Flat	206	532 44 85-96	Bracket Mount Latch Cruise
51	873 90 06-00	Lock Nut 3/8-16	207	587 03 14-02	Latch Control Cruise
52	532 19 43-26	Idler V-Groove	208	596 56 41-01	Gear Sector Control Cruise
56	592 85 52-01	V-Belt, Drive	209	596 86 98-01	Rod, Control, Cruise G
64	532 19 78-65	Shaft Asm. Pedal Brake Control	210	532 40 09-80	Rocker, Asm. Pedal, Control
69	532 42 33-03	Hairpin Soft Zink .059 x 1.125	211	532 12 01-83	Bearing Nylon
73	596 13 65-01	Bolt, Hex, Head, 5/16-18 x 1-1/2	213	532 40 31-19	Handle Parking Brake
92	595 30 57-01	Screw, Hexagon, 5/16-18 x 1-1/4	214	532 42 12-63	Pedal Forward Pad
99	582 40 45-01	Rod Bypass	215	586 60 65-02	Pedal Reverse Pad
116	596 13 57-01	Nut, Lock, Prvl, Torq, 5/16-18 x .68	216	532 19 61-31	Bracket Pulley Idler
125	817 00 05-12	Screw 5/16-18 x 3/4	221	532 40 31-87	Retainer Spring Clip Handle
143	596 03 07-01	Screw, Hexagon, 5/16-18 x 1/2	222	879 21 20-10	Washer 21/32 x 1-1/4 10 Ga.
153	532 00 44-97	Retainer Spring	225	532 40 33-19	Keeper Belt Trans.
159	596 02 95-01	Pin, Cotter, 1/8 Dia x 3/4	227	596 13 59-01	Bolt, Hex, 5/16-18 x 3/4, Clr, Zinc
160	596 02 94-01	Clip, Retainer "M"	325	585 66 85-02	Bracket
161	532 10 57-09	Spring, Return, Clutch	326	585 67 08-02	Bracket
163	593 86 10-01	Rod, Ctrl, K57R, K46	336	587 25 96-02	Bolt, 5/16-18 x 1-3/4, Flanged
166	532 42 91-64	Nut Push .625			
167	532 40 52-57	Latch Brake Parking			
170	532 19 43-22	Keeper Belt Centerspan			
171	596 13 63-01	Bolt, Cup, Head, 3/8-16 x 2			

NOTE: All component dimensions given in U.S. inches
1 inch = 25.4 mm

TRACTOR -- MODEL NO. TS 146TXD (96041043600), PRODUCT NO. 960 41 04-36
ENGINE **24**

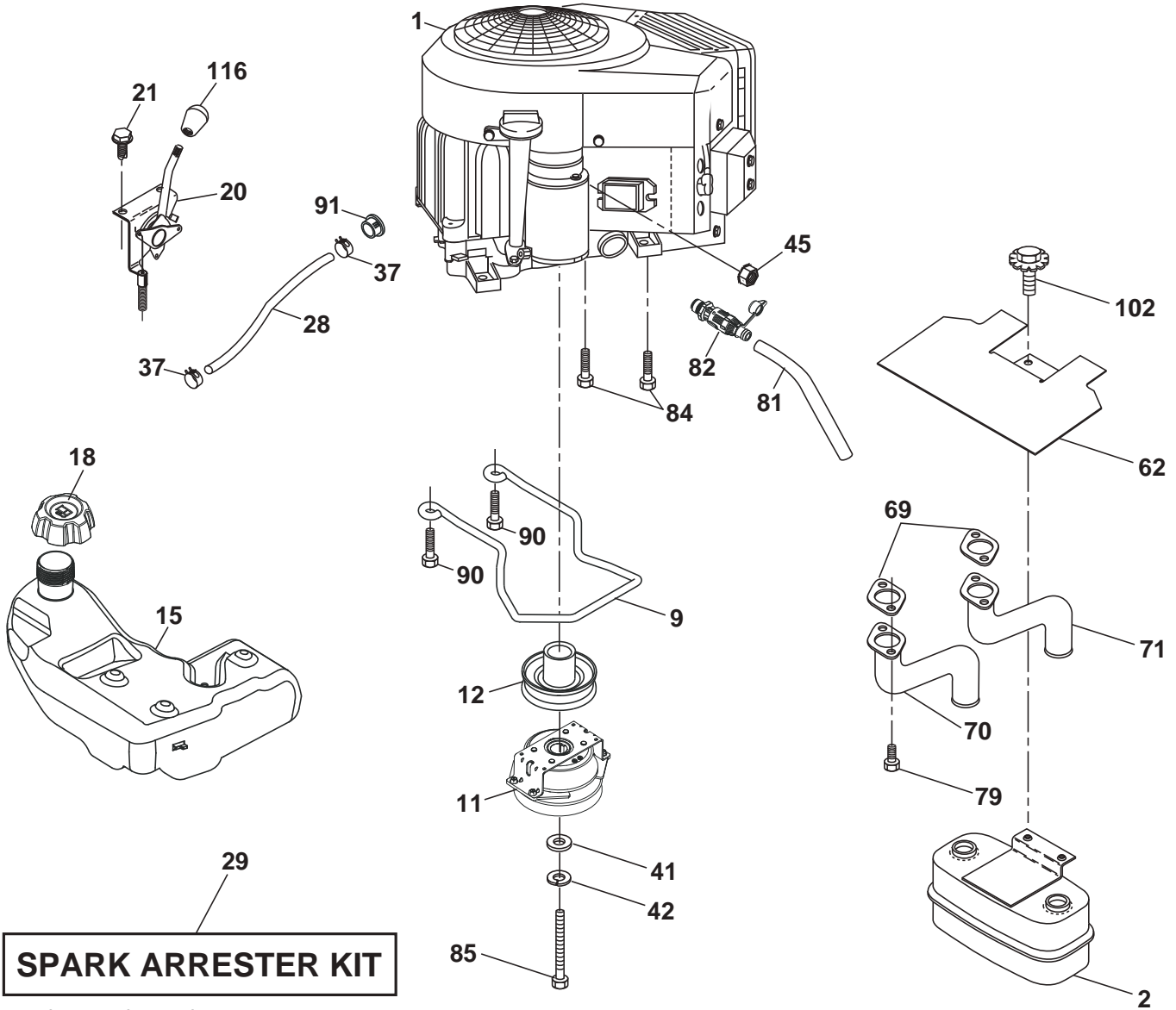

SPARK ARRESTER KIT

engine-tex_bs-2cyl_170

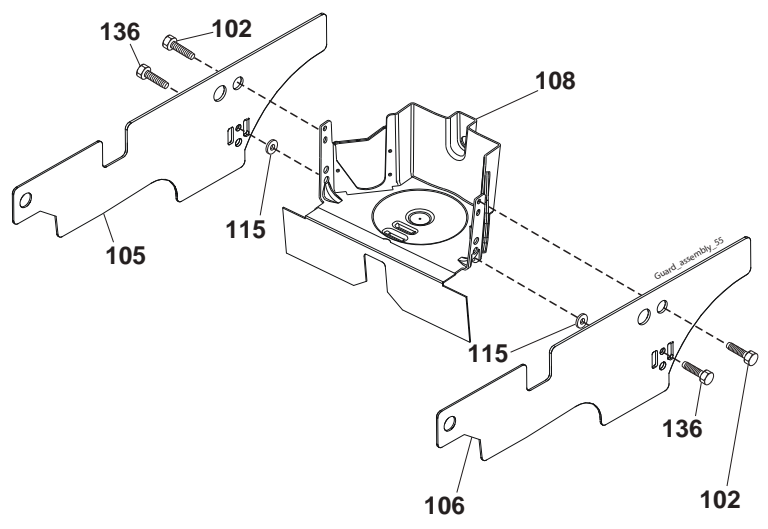

**TRACTOR -- MODEL NO. TS 146TXD (96041043600), PRODUCT NO. 960 41 04-36
ENGINE 24**

KEY NO.	PART NO.	DESCRIPTION
1	- - - - -	Briggs&Stratton 44U777-0006-B5 (597360001)(Order parts from engine manufacturer.)
2	589 81 87-01	Muffler
9	501 83 26-02	Keeper Belt Engine
11	587 24 16-01	Clutch Electric
12	532 40 50-97	Pulley Engine
15	532 43 80-28	Tank, Fuel 3 Gal.
18	585 12 48-01	Cap Fuel
20	587 24 27-01	Throttle Pro RSTART
21	596 32 17-01	Screw #10 X .075, Bos, Thread
28	532 40 11-35	Fuel Line
29	532 13 71-80	Spark Arrester Kit
37	532 12 34-87	Clamp Hose
41	532 12 61-97	Washer 1-1/2 OD x 15/32 ID x .250
42	596 23 89-01	Washer 7/16 In, Clr, Zn
45	596 13 36-01	Locknut, Keps, 1/4-20
62	532 43 40-17	Shield Heat Muffler
69	532 16 53-91	Gasket
70	581 88 11-01	Tube Exhaust LH
71	581 88 10-01	Tube Exhaust RH
79	596 13 42-02	Screw, Socket, 5/16-18 x 1, Clr, Zn
81	532 14 84-56	Tube Drain Oil Easy
82	532 42 82-87	Valve Oil Drain
84	817 06 06-20	Screw
85	501 60 66-01	Bolt 7/16-20 x 3.75 Gr. 5
90	817 00 06-16	Screw 3/8-16 x 1
91	532 18 74-95	Bushing 1.375 OD
102	817 00 05-12	Screw 5/16-18 x 3/4
105	501 26 86-02	Shield Side LH
106	501 26 87-02	Shield Side RH
108	587 17 95-11	Cover Pulley Engine w/SHLD 46"
115	532 43 17-61	Palnut #10
116	539 13 26-24	Knob Shift
136	596 43 40-01	Screw, #10 x 0.500, Bos, Thread

NOTE: All component dimensions given in U.S. inches
1 inch = 25.4 mm

Engine Power Rating Information

The gross power rating for individual gas engine models is labeled in accordance with SAE (Society of Automotive Engineers) code J1940 (Small Engine Power & Torque Rating Procedure), and rating performance has been obtained and corrected in accordance with SAE J1995 (Revision 2002-05). Torque values are derived at 3060 RPM; horsepower values are derived at 3600 RPM. Actual gross engine power will be lower and is affected by, among other things, ambient operating conditions and engine-to-engine variability. Given both the wide array of products on which engines are placed and the variety of environmental issues applicable to operating the equipment, the gas engine will not develop the rated gross power when used in a given piece of power equipment (actual "on-site" or net power). This difference is due to a variety of factors including, but not limited to, accessories (air cleaner, exhaust, charging, cooling, carburetor, fuel pump, etc.), application limitations, ambient operating conditions (temperature, humidity, altitude), and engine-to-engine variability. Due to manufacturing and capacity limitations, Briggs & Stratton may substitute an engine of higher rated power for this Series engine.

TRACTOR -- MODEL NO. TS 146TXD (96041043600), PRODUCT NO. 960 41 04-36
STEERING ASSEMBLY **41**

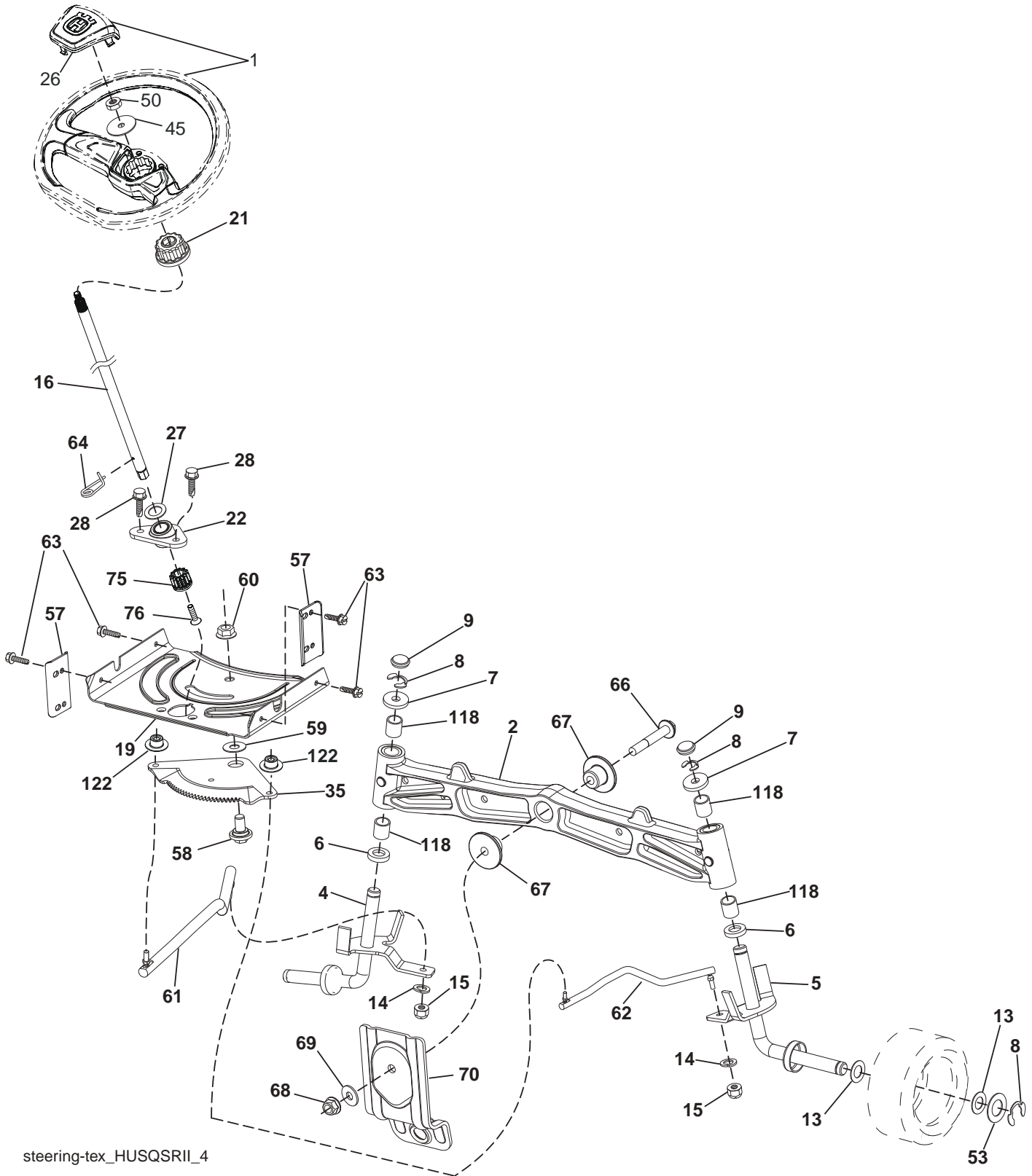

steering-tex_HUSQSR11_4

**TRACTOR -- MODEL NO. TS 146TXD (96041043600), PRODUCT NO. 960 41 04-36
STEERING ASSEMBLY **41****

KEY NO.	PART NO.	DESCRIPTION
1	597 86 61-01	Wheel, Steering, Kit (includes steering wheel and cap)
2	532 41 35-91	Axle Asm., Front
4	532 40 30-87	Spindle Asm., LH
5	532 40 30-88	Spindle Asm., RH
6	532 00 62-66	Washer Thrust 0.75 x 1.23
7	532 12 17-48	Washer 25/32 x 1-5/8 x 16 Ga.
8	812 00 00-29	Ring, Klip #T5304-75
9	532 12 12-32	Cap, Spindle
13	532 12 17-49	Washer 25/32 x 1-1/4 x 16 Ga.
14	596 23 87-01	Washer, Spring, Lock, 381ID x .680
15	873 54 06-00	Nut, Crown Lock 3/8-24 unf
16	587 01 60-02	Shaft Steering
19	532 19 47-29	Plate Steering
21	586 84 02-01	Adapter, Wheel Steering Splnd Alum
22	585 02 98-02	Bearing Subasm Shaft Steer Low
26	594 94 91-01	Wheel Steering, Cap
27	596 93 34-01	Washer, Plain
28	817 00 06-12	Screw 3/8-16 x 3/4
35	532 19 47-32	Gear, Sector Plate
45	587 01 64-01	Washer 3/8 ID 2-3/8 OD 12 Ga. PLTD
50	873 90 06-00	Nut Lock Flg. 3/8-16 unc
53	532 18 89-67	Washer Hardened .793 x 1.637 x .060
57	532 40 74-65	Bracket Upstop
58	532 19 47-47	Bolt Shoulder Sector Pivot CFM
59	532 19 47-48	Washer Thrust Sector Steering
60	873 97 10-00	Nut Flange Lock 5/8-11
61	597 07 02-02	Linkage, Asm, Draglink, LH
62	597 07 03-02	Linkage, Asm, Draglink, RH
63	817 00 05-12	Screw 5/16-18 x 3/4
64	532 19 98-49	Retainer Clip Spring Steering
66	871 02 07-48	Bolt Hex Fghd 7/16-14 x 3 Serr
67	532 19 47-37	Bushing PM Front Axle
68	873 90 07-00	Nut Lock Flange 7/16-14 Gr. 5
69	532 19 91-62	Washer 1.5 x .505 x .118
70	585 33 88-01	Bracket Deck Susp. Front
75	580 68 37-01	Pinion
76	580 68 36-01	Screw Head Sock
118	532 40 60-13	Bushing Axle
122	532 44 49-62	Cap Gear Sector TFX

NOTE: All component dimensions given in U.S. inches
1 inch = 25.4 mm

TRACTOR -- MODEL NO. TS 146TXD (96041043600), PRODUCT NO. 960 41 04-36
MOWER DECK 44

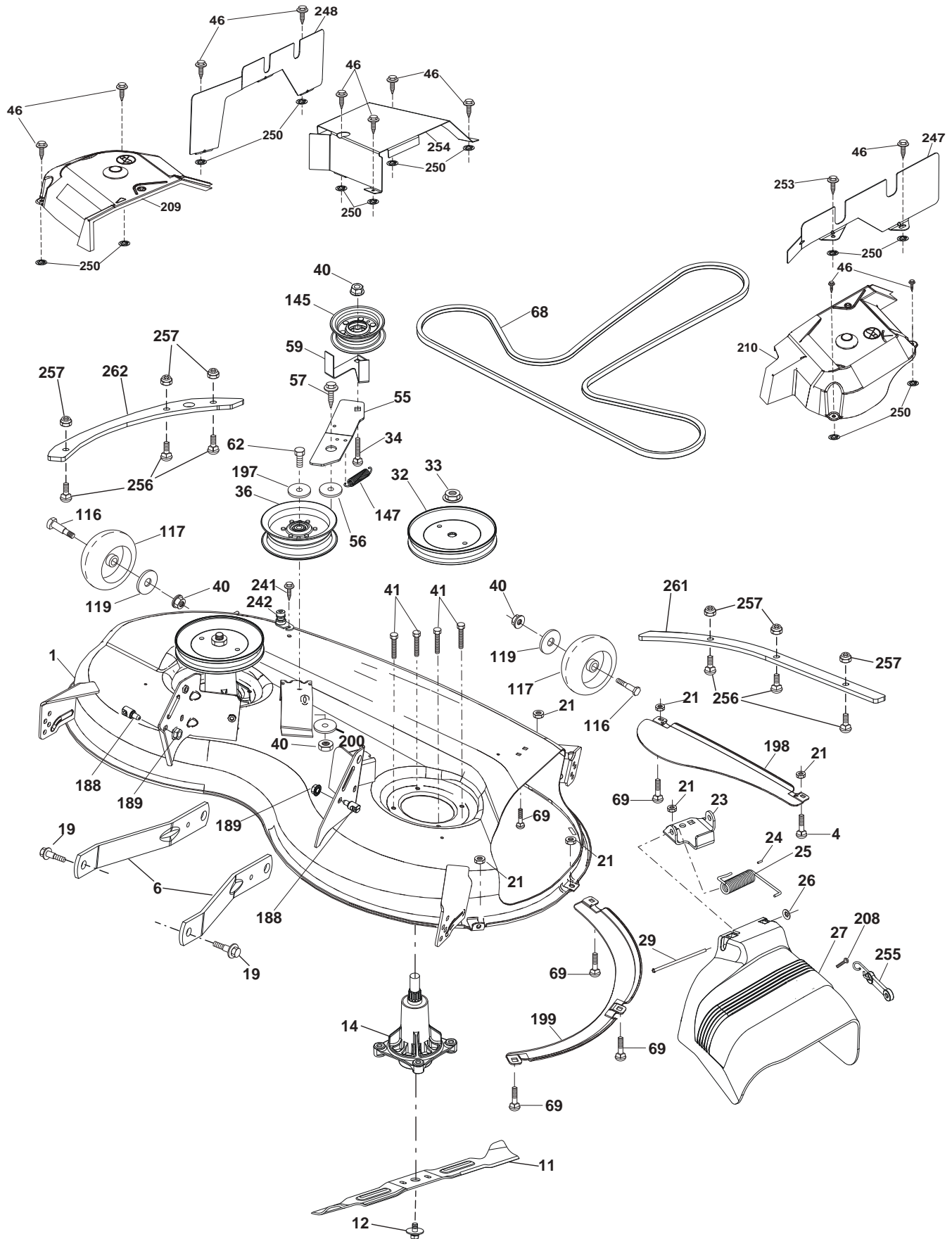

46_tex_elect_20_r1

**TRACTOR -- MODEL NO. TS 146TXD (96041043600), PRODUCT NO. 960 41 04-36
MOWER DECK 44**

KEY NO.	PART NO.	DESCRIPTION	KEY NO.	PART NO.	DESCRIPTION
1	583 97 57-01	Kit SVC Deck	116	596 43 44-04	Bolt, Shoulder, 3/8-16 x 3-5/8"
4	596 03 05-01	Bolt, Hex, Hd, 5/16-18 unc x 3/4	117	589 52 73-01	Wheel, Gauge
6	532 19 51-86	Arm Suspension	119	596 13 49-01	Washer, Plain, 3/8 x 7/8
11	532 40 53-80	Blade Mower	145	532 19 31-97	Pulley Idler
12	584 30 93-01	Screw	147	532 19 72-51	Spring, Drive
14	587 81 97-01	Kit, Mandrel, Nongreaseable, Tall (includes mandrel and bolts)	188	593 82 40-01	Stud w/ "D" Anti-Rotation
19	532 19 65-39	Bolt, Shoulder	189	596 13 57-01	Nut, Lock, Prvl, Torq, 5/16-18 x .68
21	596 04 05-01	Nut, Lock, Hex, Prvl, 5/16-18	197	596 13 32-01	Washer 13/32 x 13/16 x 12 Ga
23	532 19 25-57	Bracket, Deflector	198	532 40 31-49	Baffle Center Front
24	532 10 53-04	Cap, Sleeve	199	532 40 31-50	Baffle Front RH
25	532 19 70-26	Spring, Torsion, Deflector	200	532 41 35-24	Washer 13/32 x 1 x 1/2 11 Ga.
26	532 11 04-52	Nut, Push	208	817 67 06-08	Screw THDROL 3/8-16 x 1/2
27	597 24 71-01	Shield, Deflector, Asm.	209	588 80 88-01	Cover Asm Mandrel LH
29	595 29 70-01	Rod, Hinge	210	532 43 23-96	Cover Asm Mandrel RH
32	532 19 74-73	Pulley, Mandrel	241	532 15 29-27	Screw TT #10-32.5 3/8, Flange
33	596 13 48-01	Nut, Hex, 9/16-18 x 1.01	242	532 41 55-98	Washout Port
34	596 13 61-01	Bolt, Carr, Sh, 3/8-16 x 1-1/2, Gr. 5	247	532 43 02-63	Shield Deck RH
36	532 19 73-79	Pulley, Idler, Flat	248	532 43 02-62	Shield Deck LH
40	873 90 06-00	Nut, Lock Flg. 3/8-16 unc	250	532 42 30-62	Palnut 1/4
41	584 95 39-01	Bolt Hex Washer Head 3/8-16 x 1.19	253	532 42 73-50	Rivet
46	532 13 77-29	Screw	254	532 43 02-64	Cover Asm Rear
55	532 19 72-49	Arm, Idler	255	532 43 60-87	Kit Bungee
56	532 19 90-92	Spacer, Retainer	256	592 80 78-01	Bolt 1/4-20 x 1" Zn, Square Neck
57	817 00 06-16	Screw Hexwsh Thd 3/8-16 x 1	257	873 90 04-00	Nut Hex Flange 1/4-20 unc
59	532 14 10-43	Guard, Tuv Idler (94)	261	589 48 18-05	Plate Reinforcement Front
62	874 52 06-36	Bolt 3/8-16 unc x 2-1/4 Gr. 5	262	589 48 20-05	Plate Reinforcement Side
68	532 40 51-43	V-Belt	--	596 23 54-01	Replacement Mower, Complete
69	596 13 64-01	Bolt, Cup, Head, 5/16-18 x 5/8	NOTE: All component dimensions given in U.S. inches 1 inch = 25.4 mm		

TRACTOR -- MODEL NO. TS 146TXD (96041043600), PRODUCT NO. 960 41 04-36
MOWER LIFT 45

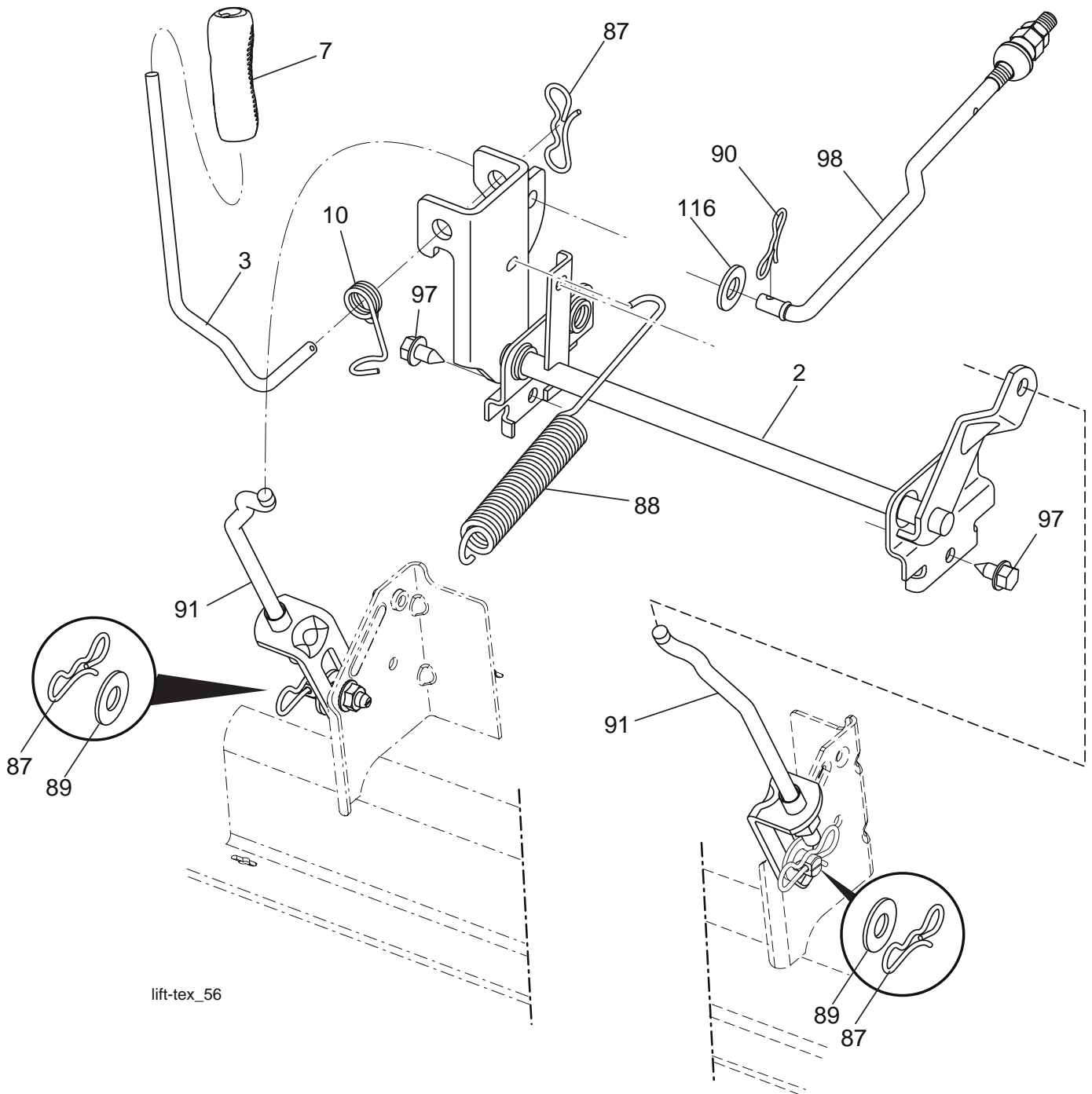

lift-tex_56

KEY NO.	PART NO.	DESCRIPTION
2	532 42 20-27	Shaft Asm., Lift
3	594 01 80-01	Lever, Lift, Handle
7	580 96 23-01	Grip, Lever
10	532 19 63-14	Spring Torsion
87	532 19 42-09	Pin Cotter 7/16 Bow Tie Lock
88	532 41 07-10	Spring Lift Assist
89	819 19 19-12	Washer Clear Zinc
90	532 19 42-08	Pin Cotter 5/16 Bow Tie Lock

KEY NO.	PART NO.	DESCRIPTION
91	589 46 48-03	Link Assy, Lift, Rear
97	817 00 06-12	Screw 3/8-16x.75 Smgml. Tap/R.Z
98	581 50 69-03	Link Assy, Front, Mwr, Susp
116	594 97 65-01	Washer, Round 15/32x 15/16x.065

NOTE: All component dimensions given in U.S. inches
 1 inch = 25.4 mm

**TRACTOR -- MODEL NO. TS 146TXD (96041043600), PRODUCT NO. 960 41 04-36
SEAT ASSEMBLY 42**

***OPTIONAL**

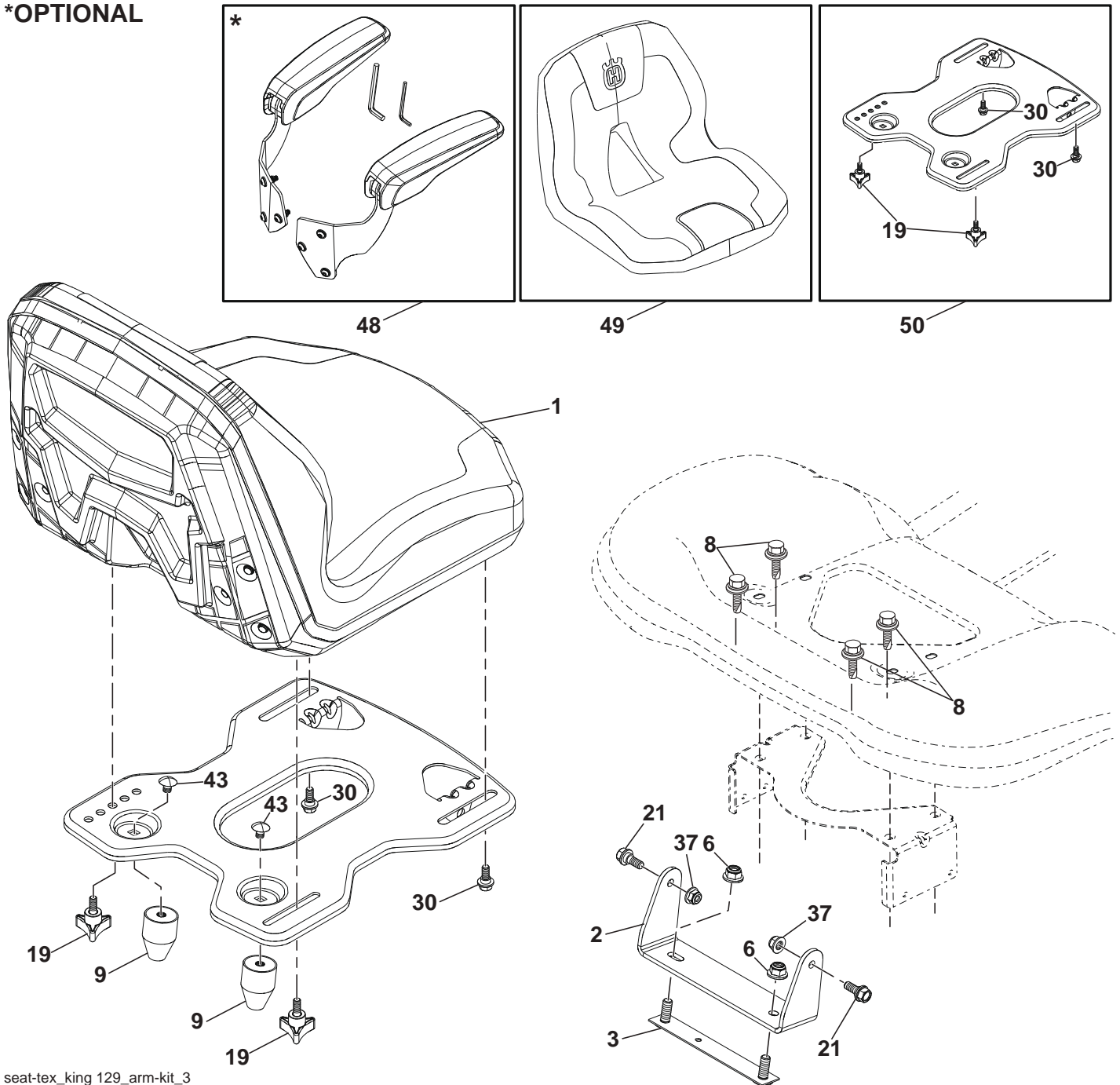

seat-tex_king 129_arm-kit_3

KEY NO.	PART NO.	DESCRIPTION
1	597 65 81-01	Seat, SK150/129 w/o Armrests (includes seat cover key# 49)
2	597 32 99-02	Bracket, PNT, PVT, FNDR, Seat EDIP
3	590 77 76-02	Bracket Asm, Reinf. FNDR, EDIP
6	521 99 65-02	Nut, Hex, Lock w/Flange 3/8-16
8	532 17 18-77	Bolt 5/16-18 unc x 3/4 w/Sems
9	597 78 51-01	Bumper, Rubber, Isolator
19	597 78 31-01	Knob, 3 Wing 5/16-18, CLR, ZN
21	596 24 07-01	Bolt, Hex 5/16-18 x 21/32

KEY NO.	PART NO.	DESCRIPTION
30	597 78-18-01	Bolt, Hex, Should 5/16-18 unc ZPB
37	594 94 44-01	Nut, Hexagon, Flange 5/16-18
43	597 86 93-01	Bolt, Carri, Cqur 3/8 x .45, CLR, ZN
48	597 65 82-03	Service Kit, 15", Seat Arm
49	597 95 94-01	Cover, Husq. 15", (SK129) Seat
50	598 00 16-01	Service, Kit, Seat Pan (includes all components illustrated in box for Key# 50)

NOTE: All component dimensions given in U.S. inches
1 inch = 25.4 mm

